



**HAMPSTEAD SCHOOL**

Learning together Achieving together

Y11 – Y12

Summer Bridging Tasks

2025

**FURTHER MATHS**

Name: \_\_\_\_\_

- You should spend some time during the summer holidays working on the activities in this booklet.
- You will be required to hand this work in during your first lesson at the start of Year 12 and the content may be used to form the basis of your first assessments.

- You should try your best and show commitment to your studies.
- We are really looking forward to you coming to Hampstead School Sixth Form and studying Further Maths



**HAMPSTEAD SCHOOL**  
Learning together Achieving together

# Year 11 -> 12

## Summer Bridging Work

### A-Level Further Maths

## Task

- Complete the attached problem-solving questions
- Your teacher will check your work in September
- You will mark your answers in September as well

# Have a lovely summer!



## Circle areas

Can you work out the shaded area in the diagram (the line shown just touches the smaller circle)?

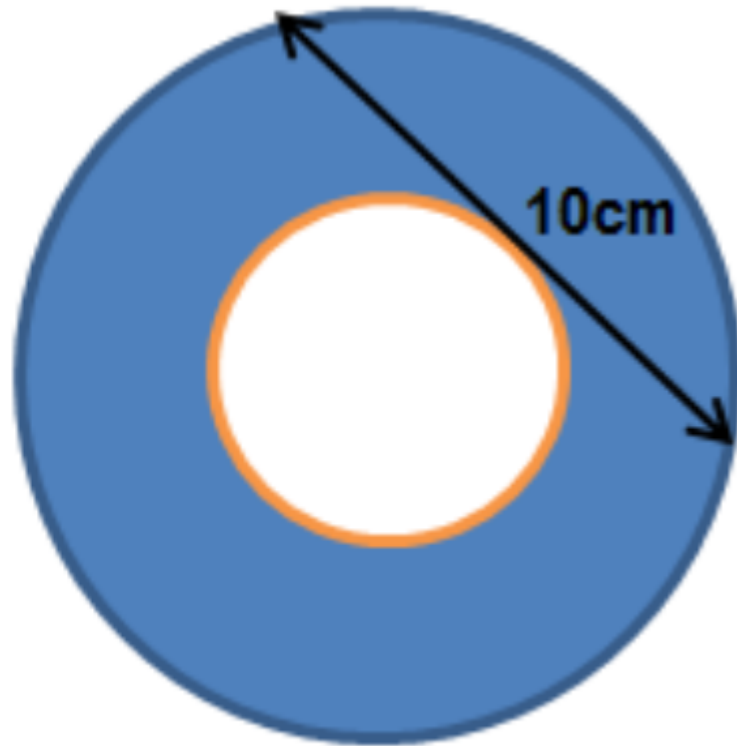

Find the value of

$$\frac{99}{100} \times \frac{80}{81} \times \frac{63}{64} \times \frac{48}{49} \times \frac{35}{36} \times \frac{24}{25} \times \frac{15}{16} \times \frac{8}{9} \times \frac{3}{4}.$$

Write your answer in the form  $\frac{a}{b}$ , where  $a$  and  $b$  are positive integers with no common factors other than 1.

A point  $E$  lies outside the rectangle  $ABCD$  such that  $CBE$  is an equilateral triangle. The area of the pentagon  $ABECD$  is five times the area of the triangle  $CBE$ .

What is the ratio of the lengths  $AB : AD$ ?

Write your answer in the form  $a : 1$ .

A sequence is defined as follows:

$$u_1 = 123.$$

For  $n \geq 1$ , define  $u_{n+1} =$  the sum of the squares of the digits of  $u_n$ .

For example,  $u_2 = 1^2 + 2^2 + 3^2 = 14$ ,  $u_3 = 1^2 + 4^2 = 17$ .

What is the value of  $u_{100}$ ?

Four semicircles are drawn on the sides of a rectangle with width 10 cm and length 24 cm. A circle is drawn that passes through the four vertices of the rectangle.

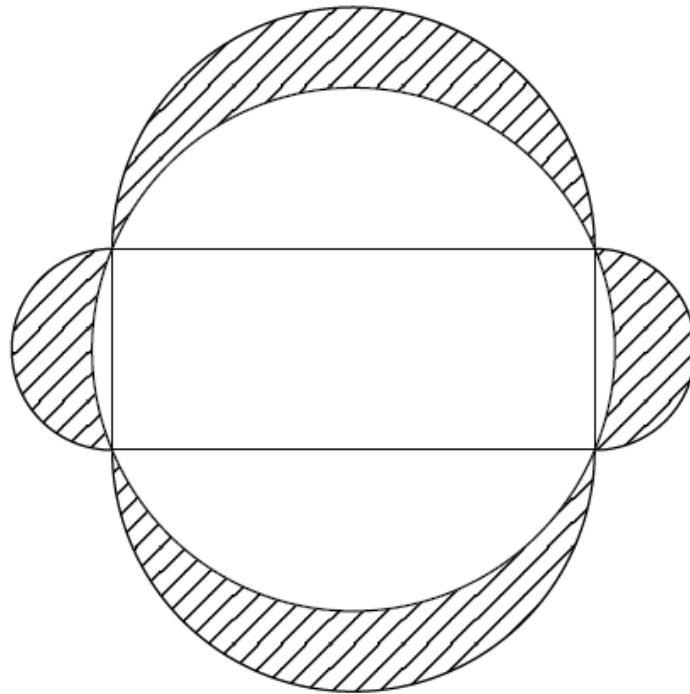

What is the value, in  $\text{cm}^2$ , of the shaded area?

Alfred, Brenda, Colin, David and Erica have to sit on a row of five chairs. Alfred does not want to sit next to Brenda. David does not want to sit next to Erica.

In how many ways can these five people arrange themselves and ensure the above conditions are met?

(a) Which positive integer in the range from 1 to 250 has more different prime divisors than any other integer in this range?

[3 marks]

(b) When  $n = 5$  the product  $n(n + 1)(n + 2)$  can be written as the product of four distinct primes. Indeed, when  $n = 5$

$$n(n + 1)(n + 2) = 5 \times 6 \times 7 = 2 \times 3 \times 5 \times 7.$$

What is the least positive integer  $n$  such that  $n(n + 1)(n + 2)$  can be written as a product of *five* distinct primes? [3 marks]

Find the value of

$$\left( \left( 2^{\frac{3}{4}} + 1 \right)^2 + \left( 2^{\frac{3}{4}} - 1 \right)^2 \right) \left( \left( 2^{\frac{3}{4}} + 1 \right)^2 + \left( 2^{\frac{3}{4}} - 1 \right)^2 - 2^2 \right).$$

The points  $A(1, 2)$  and  $B(-2, 1)$  are two vertices of a rectangle  $ABCD$ . The diagonal  $CA$  produced passes through the point  $(2, 9)$ . Calculate the coordinates of the vertices  $C$  and  $D$ .

The inequalities  $x^2 + 3x + 2 > 0$  and  $x^2 + x < 2$  are met by all  $x$  in the region:

- (a)  $x < -2$ ;
- (b)  $-1 < x < 1$ ;
- (c)  $x > -1$ ;
- (d)  $x > -2$ .